

Echomac[®] FD-6/6A

Ultrasonic Instrument for Flaw Detection, Thickness, and Dimensional Measurement in Tube & Bar



Inspection Features

Superior Performance

- GE Qualified as of 9-6-2016 for P3TF31 Class A & B, & P29TF82 Class A & B (Model 6A only)
- Vivid, real time, flicker free full color display of test signals, thresholds and settings.
- High Signal-to-Noise ratio.
- Up to 32 Independent Channels in one Instrument.
- 16 step damping adjustment for precise resolution.
- Wide choice of band pass filters.
- Negative square wave pulse echo or pitch-catch through transmission optimize transducer efficiency.
- Meets API, ASTM & EN standards.
- Excellent repeatability of test results.

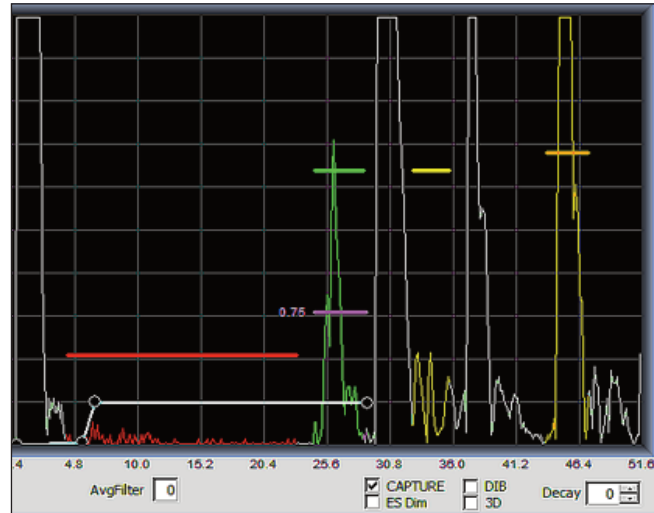

A-Scan display in the UT Screen shows the setup for Channel 1 with a gate interface and 4 gate thresholds.

Gate	A	B	C	D
Gate	<input checked="" type="checkbox"/> Gate A	<input checked="" type="checkbox"/> Gate B	<input checked="" type="checkbox"/> Gate C	<input checked="" type="checkbox"/> Gate D
Sync	IP	IP	IF	IF
Start	77.48	92.04	44.90	58.94
Width	8.32	9.10	8.06	10.14
Thresh	35	21	30	25
Gain	0.00	0.00	0.00	0.00
Pol.	POS	POS	POS	NEG
Count	1	1	1	1

Gate Dialog Box in the UT Screen

Versatile, Intuitive Operation

- Set up and control all key test parameters on one screen with a click of the mouse or keyboard.
- Move thresholds by selecting and dragging on screen.
- Adjust parameters for several channels at once with the "Global" key. Or easily copy a group of test parameters from one channel to another.
- Follow up test results and supervise operators remotely.
- Versatile, robust recorder functions and comprehensive logging of results for tracking setups and recordings.
- Full tracking of end suppression, defect marking capability, and customizable data retention.
- Seamless Integration with existing mill operations.

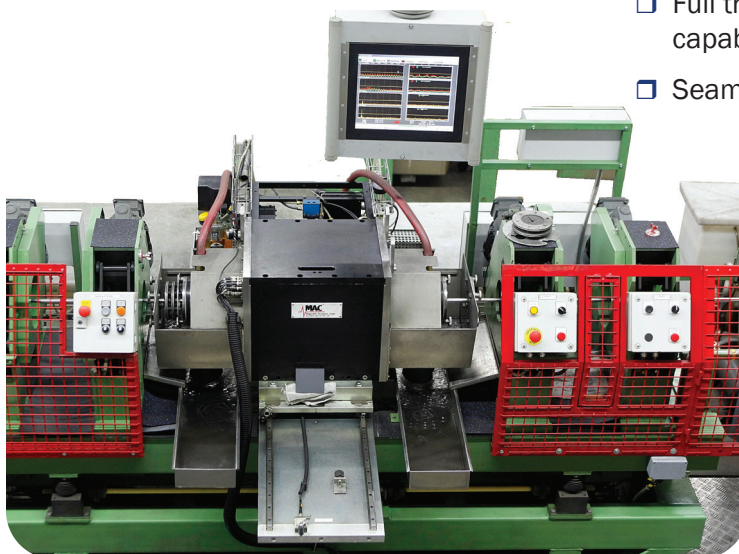

Echomac® electronics installed with an Echomac rotary transducer unit to test stainless steel and titanium alloys in heat exchanger tubing

Echomac Operation and Control

Ultrasonic Control Panel - UT Screen

Provides full access and display of ALL ultrasonic test parameters. A-scan captures infrequent flaw echoes of short duration. Up to 4 measurement gates can be employed for each channel with graphic adjustment, live peak and other relevant test results are displayed real time. A Strip Chart provides an elapsed time linear display. All parameter settings from one channel can be easily copied to additional channels or adjust globally.

Multi Channel View - Multi Screen

Displays A-scan and Strip Chart of up to 32 individual channels or functional groups*, simultaneously. The strip chart shows the peak captured signal levels in color highlighted outlines, along with the numerical peak measurement within each gate. Graphic editing of visual devices such as gate, DAC, and scope position provide convenient adjustment.



Tracking System - Track Screen

Accurately track product through FD6/6A test channels so each channel can be properly set for end suppression and flaw tracking through an encoder or simulated timer clock. Track screen provides control for all the parameters relating to the production line, alarm matrix routing, output control and sorting criteria. Complex arrangement and multiple line speed calibration are employed.

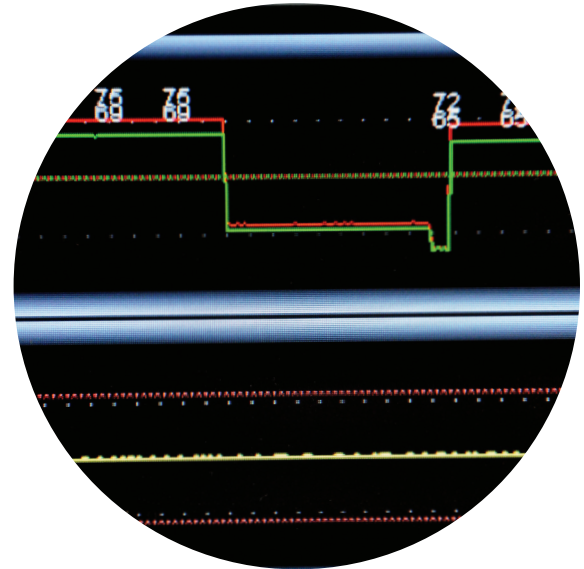

Multi Screen Strip Chart view of peak signal levels & numerical value

Production Recorder - Chart & Batch Screen

Strip charting and defect logging of all events for up to 32 individual channels or functional groups*, in both live or replay mode, is included as standard. Each chart clearly indicates Accept/Reject status. It also displays piece number and length, start time, date, line speed, and number of sample points taken. Batch screen manages record folders and production information input.

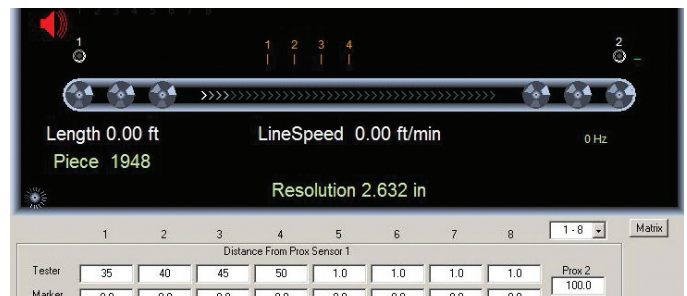

* A Functional group consists of channels with similar test functions such as channels for detecting longitudinal defects. These related channels are mapped into one chart for easy viewing, adjusting, or copying..

Features of Echomac Electronics

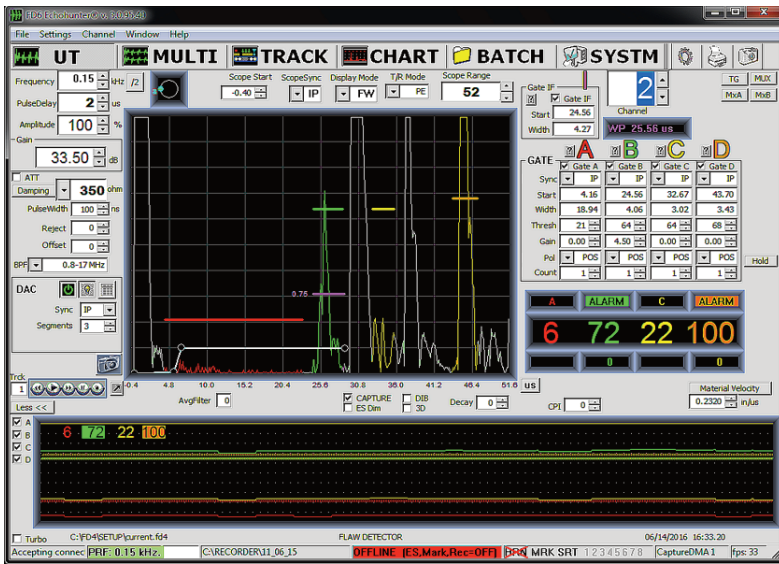

- ☑ Includes up to 32 independent test channels in a single computer.
- ☑ Increased Gain Range with fine resolution and improved linearity.
- ☑ User configurable criteria for flaw, lamination and thickness gauging, independently for each channel.
- ☑ Adjustable pulse firing sequence to avoid crosstalk in multi-channel applications.
- ☑ Four independent flaw gates for each channel with improved resolution.
- ☑ 15 segments distance amplitude correction (DAC).
- ☑ Improved DAC interface and resolution.
- ☑ Very high resolution thickness measurement for each channel.
- ☑ Programmable for Pulse Echo or Through Transmission.

Echomac FD-6/6A Applications

- ☑ Inspect carbon, duplex, or stainless steels, aluminum, titanium, copper and other metals and alloys.
- ☑ Detect flaws and measure dimensions and wall thickness.
- ☑ Test tube & bar for internal defects and inclusions.
- ☑ Inspect for tube ovality and eccentricity.
- ☑ Inspect strip before welding.
- ☑ Upgrade and/or replace older ultrasonic testers & systems.
- ☑ Use with rotary, spin-the-tube, squirter, bubbler installations.

Echomac® Rotaries rotate up to 32 transducers around the tube or bar, as it is moved through the test. Water is continuously circulated in the transducer housing to maintain the couplant for the UT signals.

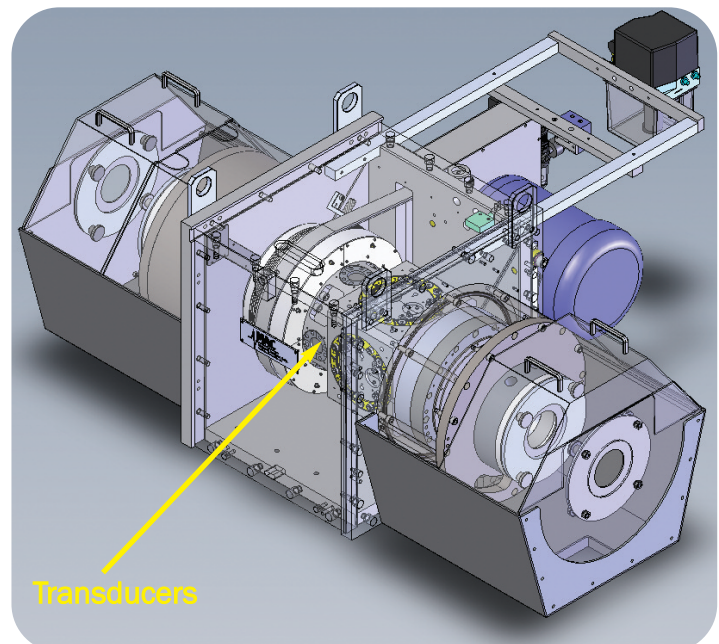

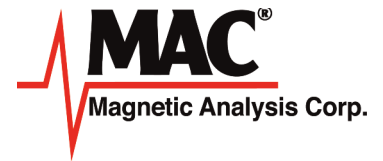

Echomac® FD-6/6A Instrument Technical Data

PULSER

TYPE OF PULSER	Negative Square
PULSER VOLTAGE	225 Vp, max @50 Ohms damping (adjustable from 0 to 100% in 1% steps)
PULSE WIDTH	30 to 500 ns (adjustable in 5 ns steps)
DAMPING	50 to 350 Ohms (adjustable in 20 Ohms steps)
RISE TIME	10 ns or less
PULSE REPETITION FREQUENCY (PRF)	10Hz To 15 kHz (adjustable in 10Hz steps)
PULSE DELAY	1 to 1000 μ s (adjustable in 1 μ s steps)
MODES OF OPERATION	Pulse-Echo or Through Transmission (Pitch-Catch)

RECEIVER

GAIN RANGE	0 to 100 dB (adjustable in 0.1 dB steps)
DIFFERENTIAL GAIN	Adjustable in the full gain range for each gate interval
FREQUENCY RANGE (-3dB)	0.6 Hz to 27 MHz
BAND PASS FILTER (-3dB)	0.6-2.0 MHz, 0.8-17.0 MHz, 1.1-5.0 MHz, 2.0-10.0 MHz, 5.0-15 MHz, and 12-27 MHz
INPUT IMPEDANCE	1 k Ohms
OSCILLOSCOPE DISPLAY	FE, PHE, NHE and RF
LINEAR REJECT	Digital (adjustable from 0 to 40% in 1% steps)

GATE

NUMBER OF GATES	4 x Measurement Gates and 1 x Interface Gate
GATE SYNCHRONIZATION	Internal Pulse (IP or Main Bang) or Interface (IF)
DELAY AFTER INTERFACE	None, Pre-trigger available
GATE START RANGE	20ns to 1000 μ s (adjustable in 10ns steps)
GATE WIDTH	20ns to 1000 μ s (adjustable in 10ns steps)
DEFECT EVALUATION	Alarm threshold (adjustable from 0 to 100% of FSH in 1% steps)
ALARM LOGIC	Positive or negative (independent on each gate)
PEAK & VALLEY DETECTION	For positive alarm mode, the largest signal within the gate is held until it is recorded on strip chart In negative alarm mode, the smallest signal is held in a similar manner. Peak value is processed by hardware

DISTANCE - AMPLITUDE CORRECTION (DAC)

DAC CURVE	15 segments, limited to 16k points per channel, with easy setup by dragging with mouse or operator entry in table
DAC DYNAMIC RANGE	0 to 80dB (Max. DAC Gain + Gate Gain + Main Gain = 100dB)
DAC RESOLUTION	10ns
DAC UPDATE	40dB/ μ s
DAC TRIGGER	Main Bang or Interface (with Pre-trigger)

Model 6A Only: GE Certification: Integrated system with the Pulser/Receiver/Recorder version 3.0.95.41 has been qualified per Procedure UT_1335 as of Sept. 6, 2016 for P3TF31 Class A and B and P29TF82 Class A and B.

continued next page

THICKNESS CIRCUIT

THICKNESS RESOLUTION	1ns approximately 0.00012" (~3 µm) for steel 1020 in PR mode (higher resolution for OD measurement)
THICKNESS MODES	Average and min/max capture for rotary
ERROR DETECTION CIRCUIT	An adjustable measuring gate limits thickness measurement to a specific location, prohibiting false readings from missing echoes. Slew rate control restricts measurements from rapidly changing from previous measurement in order to minimize false signals.
ALARM THRESHOLDS	Independently settable for minimum and maximum deviations from nominal values

A-SCAN DISPLAY

DIGITIZATION	100 MHz, 8 bit, independent for each channel
DEPTH	500 points
RANGE	1 µs or greater
SYNC	IP or IF with delay
PROCESSING	Each channel has a dedicated ADC processor, and DMA engine for capturing and displaying consecutive traces. Specialized peak capture mode of operation is implemented in both hardware and software.
PERSISTENCE/DECAY	Previous traces can be shown in fading intensities to hold infrequent events. DIB processing mode allows much longer and infinite hold.

DIMENSIONAL MEASUREMENT

DIMENSIONAL MEASUREMENT	Three-Transducer mode of operation for simultaneous measurement of OD, ID and wall thickness of tubes. Two transducers are located on opposite sides of the tubes; the third transducer has a fixed artificial target for water velocity compensation due to temperature variation. Eccentricity mode is available
--------------------------------	--

STRIP-CHART PRESENTATION & RECORDING

GENERAL	Strip-charts are displayed on the monitor with the A-scan and setup parameters, or separately.
NUMBER OF TRACES	Any and all gates up to 32 channels
RECORDING	There are 32 recording channels and 4 gates
REPORTING	Summary reports containing number of pieces or length tested, number of rejects, date of test, material and customer information, are given at the end of a production run

TUBE & BAR TRACKING

TUBE & BAR TRACKING	Implemented in hardware. End suppression and defect marking are fast and high precision. Alarms Matrix fully configurable. Marking distance programmable up to 10k encoder pulses.
--------------------------------	--

COMPUTER

COMPUTER	Industry standard IBM compatible, standard rack mount computer with Windows® platform
-----------------	---

NETWORK

NETWORK	10/100 Ethernet. TCP/IP Remote application can control test parameters and view signal wave-forms.
----------------	--

OPERATING CONDITIONS

AC POWER	Under 800 VA from a 115 V or 230 V, 50 or 60 Hz line for an 8 channel installation
ENCLOSURE	Standard 19" rack-mount computer enclosure and rack mount monitor, typically housed in air conditioned cabinets. CE approved.
WEIGHT	55 lbs. (24.75 kg)
OPERATING TEMPERATURE	0 to 50 degrees C (32 to 122 degrees F)

Specifications subject to change without notice. Echomac®, EchoHunter® and MAC® are registered trademarks of Magnetic Analysis Corporation, Elmsford, NY. Windows® is a registered trademark of Microsoft Corporation.

Magnetic Analysis Corporation ~ 103 Fairview Park Drive- Elmsford, New York 10523-1544 USA ~ Tel: +1.914.530.2000 ~ info@mac-ndt.com

www.mac-ndt.com

Echomac FD-6/6A Spec 11/2017